

The Mathematics of the Casimir Effect

JONATHAN P. DOWLING

Department of Physics
University of Colorado
Boulder, CO 80309

Introduction In 1948 H. G. B. Casimir, a mathematical physicist, made a rather startling prediction. He calculated from the theory of quantum electrodynamics that if two massless, perfectly-reflecting plane mirrors were positioned parallel to each other a short distance apart at zero temperature, in a perfect vacuum, then there would arise between them a force of attraction inversely proportional to the fourth power of their separation. The force would be due solely to the interaction of the plates with the vacuum of space [1].

That the vacuum could exert a force on anything came as a bit of a surprise to most physicists. (To mathematicians it must sound like just another one of those incoherent ramblings usually attributed to physicists.) In fact, many physicists at first simply dismissed what has become known as the **Casimir effect** as patent nonsense; but that was before, when, in the mid-1950's, the effect was verified in a series of precision experiments. (Two gold mirrors are actually suspended a few microns apart and the force measured directly.) The numbers agreed with those predicted by Casimir—right on the button. (A discussion of this and other odd properties of the vacuum is given in [2].)

But what does this all have to do with mathematics? In Casimir's original theoretical calculation there comes a point when one must compare an improper integral $\int f$ to an infinite series $\sum f$, where the functional form of f is the same in both cases. In particular one needs to know $\sum f - \int f$ in order to arrive at a final numerical result. It turns out that there are two very nice formulas from classical analysis which will do the trick; one is due to Euler and Maclaurin, and the other attributed to the two mathematicians Abel and Plana.

In the course, then, of discussing some interesting physics and some beautiful mathematics I hope to convey the idea that it is possible for a few people (such as a humble mathematical physicist like myself) to do and to enjoy doing both.

QED and the Casimir effect Quantum electrodynamics, or more playfully, QED, is a theory which describes how point, charged particles interact with light [3]. *Some* of the theoretical predictions of QED agree with experiment to within one part in 10^{12} —making it the most accurate physical theory ever invented. Although “thus it has been demonstrated” that “QED” gives some very good results, the theory is also in the habit of predicting things which are quite nonsensical, or so it would seem. To arrive at the very accurate predictions of QED, physicists blatantly add and subtract badly divergent integrals as if they were finite quantities, a prescription which makes even the strongest of mathematicians wince. Worse, QED predicts that the energy density of empty space, at zero temperature, is infinite. Yes, infinite.

QED is like the “girl with the curl” ($\nabla \times \mathbf{A}$?) from the old nursery rhyme; for when she is good she is very, *very* good— but when she is bad she is *horrid*.

So for a time, in order to keep the universe from vaporizing in a blast of radiant vacuum energy, physicists pragmatically subtracted this infinite quantity from their formulas and proceeded as though it did not exist. Then along came Casimir, who resurrected the vacuum energy and haunted the pragmatists with a proof of its physical reality.

Consider the following *Gedankenexperiment*. A rectangular parallelepiped of dimensions $a \times b \times c$ is constructed from perfectly reflecting mirrors and nestled against the coordinate axes in the first octant. (See FIGURE 1a.) Call the energy in the box E_I . (Remember $E_I = \infty$.) Now place a perfectly-reflecting, mirrored partition in the box, parallel to the xy -plane, a small distance R from the origin. (See FIGURE 1b.) We assume that $R \ll a, b$, or c . Now the volume of the box is divided into two volumes; call the vacuum energy in the smaller volume E_{II} and that in the larger E_{III} . One can then operationally define an effective potential energy between the partition and the xy -plane as $\Delta E := (E_{II} + E_{III}) - E_I$. If the E 's were finite, this would of course be zero. But as things stand, ΔE has the indeterminate form $\infty - \infty$. (Indeterminate, not undefined; like the indeterminate form $0/0$, there is still hope.) Since ΔE is a function of the separation R , an effective force of attraction is gotten using $F = -\partial/\partial R(\Delta E)$.

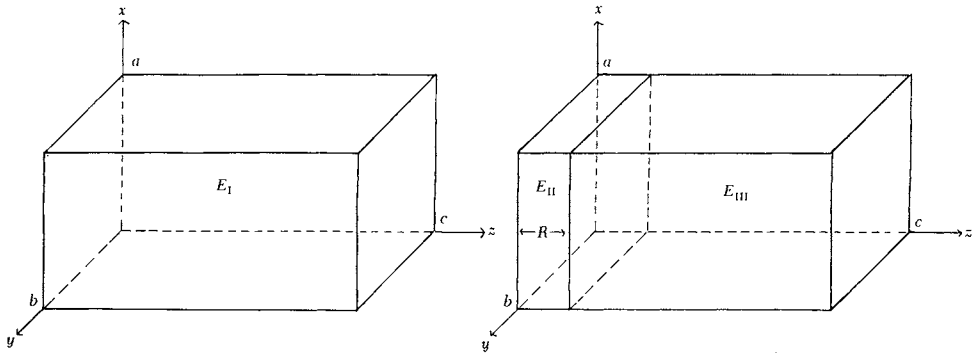

FIGURE 1a

FIGURE 1b

It turns out that E_I and E_{III} are proportional to divergent improper integrals and E_{II} to a divergent series. They diverge only cubically, and so it is possible to induce convergence by multiplying the integrands (or summand) by a factor $e^{-\lambda x}(e^{-\lambda n})$ with the understanding that $\lambda \rightarrow 0^+$ at the end of the whole calculation. When this is done, one finds it necessary to evaluate the now finite expression

$$\Delta_0^\infty(f) := \sum_{n=0}^\infty f(n) - \int_0^\infty f(x) dx, \tag{1}$$

where for this problem $f(x) = x^3 e^{-\lambda x}$. More generally, we can replace $f(x)$ by $f(x; \lambda) := f(x)g(x; \lambda)$, where $g(x; \lambda)$ is some cutoff function which satisfies

$$\lim_{x \rightarrow \infty} g(x; \lambda) = 0 \quad \lim_{\lambda \rightarrow 0^+} g(x; \lambda) = 1,$$

where the limits converge separately and uniformly. (For more details on the allowable class of functions f see [5].)

So we are done with the physics; the mathematicians may stop snickering now, and we can proceed with the investigation of the functional $\Delta(f)$.

The Euler–Maclaurin summation formula The first formula we shall consider for $\Delta(f)$ is the **Euler–Maclaurin summation formula (EMSF)**. A pedestrian derivation of this formula is given in the complex analysis text of Carrier, Krook, and Pearson [4]. I am not sure what the opposite of *pedestrian* is—but whatever it is, Hardy is it. He gives a comprehensive treatment in his wonderful book, *Divergent Series* [5]. The formula was found independently by Euler in 1732 and Maclaurin in 1742. (Euler’s

productivity is measured by the truckload, and often his results took a while to diffuse throughout Europe.) But this is not a history lesson, I'm afraid, and so no dusty morsels gathered from yellowed manuscripts in subbasement *e* of the Göttingen archives will be forthcoming.

Speaking of ancient history, though, I'd like to relate here how I first started thinking about the difference between the sum of a function and its integral. The question arose in my first course on elementary calculus (n years ago, where n is large), when I learned the **integral test for convergent series**: *If $f(x)$ decreases on the interval (n_0, ∞) , where n_0 is a positive integer, then the series $\sum_{n=n_0}^{\infty} f(n)$ and the integral $\int_{n_0}^{\infty} f(x) dx$ converge or diverge together.* Fair enough. But at the time I had a wild idea: "Do they give the same answer?" A quick counterexample dashed my foolish hopes:

$$\sum_{n=1}^{\infty} \frac{1}{n(n+1)} = \sum_{n=1}^{\infty} \left(\frac{1}{n} - \frac{1}{n+1} \right) = 1$$

$$\int_1^{\infty} \frac{dx}{x(x+1)} = \int_1^{\infty} \left(\frac{1}{x} - \frac{1}{x+1} \right) dx = \ln(2),$$

where the series is telescopic. (Nice, though, that the same partial-fraction technique allows you to do both.) I soon realized that there was no hope of getting the same answer. The sum is always just an approximation to the integral and the area under the rectangles is never the same as the area under the curve. (See FIGURE 2.) But still, I figured, they had to be related. Not being Euler... I went on to other things.

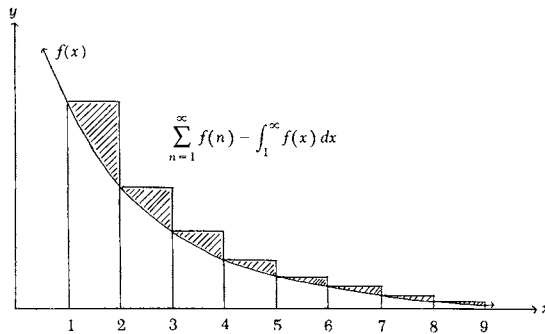

FIGURE 2

So now let us put ourselves in Euler's shoes; the saying goes something like: "As most men breathe, Euler calculated." Euler enjoyed manipulations with series. His instincts may have been to transform the integral term in $\Delta(f)$ into one; so that both terms would be on the same footing. This is easily done. Let N be a positive integer, then

$$\begin{aligned} \Delta_0^N(f) &:= \sum_{n=0}^N f(n) - \int_0^N f(x) dx \\ &= \frac{1}{2} [f(N) + f(0)] + \sum_{n=0}^{N-1} \frac{1}{2} [f(n+1) + f(n)] - \sum_{n=0}^{N-1} \int_n^{n+1} f(x) dx \\ &= \frac{1}{2} [f(N) + f(0)] + \sum_{n=0}^{N-1} \left\{ \frac{1}{2} [f(n+1) + f(n)] - \int_n^{n+1} f(x) dx \right\}. \quad (2) \end{aligned}$$

So now what? Now a typical Eulerian trick. The expression in { } above can be rewritten as

$$\begin{aligned} \{ \} &= \frac{1}{2} [f(n+1) + f(n)] - xf(x) \Big|_n^{n+1} + \int_n^{n+1} xf'(x) dx \\ &= - \left(n + \frac{1}{2} \right) [f(n+1) - f(n)] + \int_n^{n+1} xf'(x) dx \\ &= - \left(n + \frac{1}{2} \right) \left[\int_n^{n+1} f'(x) dx \right] + \int_n^{n+1} xf'(x) dx \\ &= \int_n^{n+1} \left[x - n - \frac{1}{2} \right] f'(x) dx. \end{aligned}$$

If we notice that for all $x \in (n, n + 1)$ that $[x] = n$, where $[x]$ is the usual “greatest integer less than x ,” then we can write equation (2) as

$$\Delta_0^N(f) = \frac{1}{2} [f(n) + f(0)] + \sum_{n=0}^{N-1} \int_n^{n+1} \left(x - [x] - \frac{1}{2} \right) f'(x) dx. \tag{3}$$

The factor $(x - [x] - 1/2)$ multiplying $f'(x)$ is a *sawtooth function* which we denote by $S_1(x)$. We have tacitly assumed f to be once differentiable in order to pull off the integration by parts we did. In order to continue we shall assume that f is K times differentiable on $(0, N)$. If we define $\{S_k(x)\}_{k=1}^K$ to be any sequence of functions on $(0, N)$ satisfying $S'_k(x) = S_{k-1}(x)$, we can integrate the expression (3) for $\Delta_0^N(f)$ by parts K times to get

$$\begin{aligned} \Delta_0^N(f) &= \frac{1}{2} [f(N) - f(0)] + \sum_{k=2}^{K-1} (-1)^k S_k(x) f^{(k)}(x) \Big|_0^N \\ &\quad + (-1)^{K+1} \int_0^N S_K(x) f^{(K)}(x) dx, \end{aligned} \tag{4}$$

where $f^{(k)}$ is as usual the k th derivative of f . It would be nice to pin down the functions $S_k(x)$ at this point. Euler probably reached for (or invented) the **Euler polynomials** $E_k(x)$, which have the convenient property that $E'_k(x)/k! = E_{k-1}(x)/(k-1)!$ Instead it is more common these days to invoke the **Bernoulli polynomials** $B_k(x)$ which have exactly the same property. (See [4] and [5].)

The Bernoulli polynomials can be defined implicitly via a generating function

$$\frac{te^{xt}}{e^t - 1} := \sum_{k=0}^{\infty} B_k(x) \frac{t^k}{k!} \quad (t < 2\pi)$$

and as noted above they have the property that $B'_k(x)/k! = B_{k-1}(x)/(k-1)!$ for $n = 1, 2, \dots$, which can be proved with minimal pain from the definition. The **Bernoulli numbers** are defined as $B_k := B_k(0)$ and the first few are: $B_0 = 1$, $B_1 = -1/2$, $B_2 = 1/6$, $B_3 = 0$, and $B_4 = -1/30$. In fact all odd-order B numbers beyond B_1 are identically zero, a fact we shall be needing. We shall be needing also the relationship $B_k = (-1)^k B_k(1)$.

Now if we define the functions $S_k(x) := B_k(x)/k!$ for $k = 2, 3, \dots$ on the interval $(0, 1)$, and $S_k(x)$ periodic thereafter with period 1—we can then apply all the above stated properties to expression (4) to arrive at the long-awaited

EULER–MACLAURIN SUMMATION FORMULA. Let $f(x)$ be K times differentiable on the interval $(0, N)$, with N a positive integer. Then

$$\Delta_0^N(f) = \frac{1}{2} [f(N) + f(0)] + \sum_{m=1}^{M(K)} \frac{B_{2m}}{(2m)!} [f^{(2m-1)}(N) - f^{(2m-1)}(0)] + R_K(z), \quad (6)$$

where

$$M(K) := \begin{cases} \frac{K}{2} & (K \text{ even}) \\ \frac{K-1}{2} & (K \text{ odd}), \end{cases}$$

and we have used the mean value theorem to write the remainder as $R_K(z) = (-1)^{K+1} N S_K(z) f^{(K)}(z)$ for some $z \in (0, N)$.

Recall that Casimir had $f(x) = x^3 e^{-\lambda x}$. For this function we clearly may take both N and K to ∞ . Notice that $f^{(k)}(\infty) = 0$ for all $k = 0, 1, \dots$ and that $f(0) = 0$, $f'(0) = 0$, $f'''(0) = 6$, and $f^{(k)}(0)$ is proportional to some positive power of λ for $k = 4, 5, \dots$

If we finally take the limit of $\lambda \rightarrow 0^+$ as well, the series then truncates and we are left with the result $\Delta(f) = -1/120$. This number becomes incorporated into a constant of proportionality for the parallel-plate force law $F \propto 1/R^4$, where R was the plate separation. In particular

$$F(R) = \left[-\frac{1}{120} \right] \frac{hcA\pi}{4} \frac{1}{R^4}, \quad (7)$$

where h is Planck's constant, c is the speed of light, and A the area of the plates. The negative sign indicates that the force is one of attraction. The value of $1/120$ and the fact that the force is attractive agrees well with experiments in which two gold, mirrored plates are suspended a small distance apart in a good vacuum and the resultant force measured.

The Abel–Plana summation formula Recently some physicists have recalculated the Casimir effect under the additional (hypothetical) assumption that photons have a nonzero rest mass. This modification alters the calculation somewhat and at the point where one tries to apply the EMSF... it does not work. (The series does not truncate nicely as before.) A better formula was needed. So out of the treasure chest of complex analysis was hauled the **Abel–Plana summation formula** (APSF). The only two places I have ever seen this formula are in Hardy's book [5] and in the writings of the "massive photon" people—who also got it from Hardy. We may still venture a guess of the sort: what would Abel have done? With the EMSF already known, and with his substantial experience in the field of integral equations, Abel might have leaned toward an integral formula to express the functional $\Delta(f)$.

As a start in this direction, we now detour to the most beautiful formula in elementary complex analysis

CAUCHY'S INTEGRAL FORMULA. Let $f(z)$ be analytic on some simply-connected region R and let Γ be some closed contour contained in R . If ζ is any point enclosed by Γ then

$$f(\zeta) = \frac{1}{2\pi i} \oint_{\Gamma} \frac{f(z)}{z - \zeta} dz. \quad (8)$$

From this formula all sorts of wonderful things flow. It's beautiful because it tells you in just what way an analytic function is "nice." Analyticity is not determined pointwise, but rather by a coherent unison of all the points throughout the domain. For how else could the function's value at any point ζ be determined by the function's values along *any* enclosing contour Γ ? But enough meta-mathematics. (I think that Will Rogers once said: "I never meta-mathematician I didn't like.")

So now we recall that the function $\pi \cot(\pi z)$ has an infinite partial fraction expansion, also due to Euler, given by

$$\pi \cot(\pi z) = \sum_{n=-\infty}^{\infty} \frac{1}{z-n}.$$

Hence if we choose contours Γ and $\{\Gamma_n\}_{n=0}^{\infty}$ as shown in FIGURE 3, we can apply the Cauchy formula an infinite number of times to get

$$\begin{aligned} \sum_{n=0}^{\infty} f(n) &= \frac{1}{2\pi i} \sum_{n=0}^{\infty} \oint_{\Gamma_n} \frac{f(z)}{z-n} dz \\ &= \frac{1}{2i} \oint_{\Gamma} \cot(\pi z) f(z) dz \end{aligned} \tag{9}$$

and so now $\sum f$ is a complex-contour integral. To make it a real integral we rotate the upper arm of Γ by $\pi/2$ and the lower by $-\pi/2$. The substitution: $z = x \pm i\epsilon \rightarrow \pm iy \pm i\epsilon$ will do this nicely, since $e^{\pm i\pi/2} = \pm i$. Taking $\epsilon \rightarrow 0^+$ we arrive at

$$\begin{aligned} \sum_{n=0}^{\infty} f(n) &= \frac{1}{2} \operatorname{res}_{z=0} [f(z)\cot(\pi z)] - \frac{1}{2} \int_0^{\infty} [f(iy) - f(-iy)] \cot(i\pi y) dy \\ &= \frac{1}{2} f(0) + \frac{i}{2} \int_0^{\infty} [f(iy) - f(-iy)] \coth(\pi y) dy, \end{aligned} \tag{10}$$

where the first term arises from a residue at the origin, and we have used the identity between the hyperbolic and ordinary cotangent given by: $\coth(z) = i \cot(iz)$. We have implicitly assumed that $f(z)$ is analytic on the $1/2$ plane $\operatorname{Re}\{z\} > -\delta$, for some $\delta > 0$. A further condition we shall need is that

$$\lim_{y \rightarrow \infty} e^{-2\pi|y|} |f(x + iy)| = 0$$

uniformly in any finite interval of x . (See [5].)

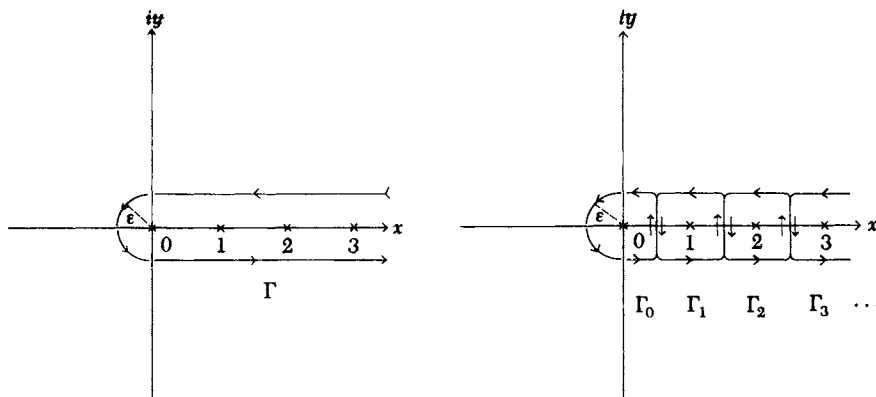

FIGURE 3

Under these same conditions we can transform the $\int f$ portion of $\Delta(f)$ to resemble the form given above for Σf . We use the following trick. (A *trick* is something you use only once—a *technique* is something you use more than once.)

$$\begin{aligned}\int_0^\infty f(x) dx &= \frac{1}{2} \int_0^\infty f(x) dx + \frac{1}{2} \int_0^\infty f(x) dx \\ &= \frac{1}{2} \int_0^\infty f(iy) d[iy] + \frac{1}{2} \int_0^\infty f(-iy) d[-iy] \\ &= \frac{i}{2} \int_0^\infty [f(iy) - f(-iy)] dy,\end{aligned}\tag{11}$$

which amounts to formally duplicating the integral and rotating the first one upwards into the complex plane by an angle of $\pi/2$, and the second downwards by the same amount. (As it stands, this manipulation is valid for a smaller class of functions than for which the final result will actually hold. For example: if $f(x) = e^{-x}$ on the left-hand side of expression (11) then the integral on the right-hand side becomes $-\int_0^\infty \sin(x) dx$ which does not converge in the normal sense. One can remedy this short-coming by introducing cut-off functions $g(x; \lambda)$ as described before—or avoid the problem altogether by using a more careful and rigorous method of deforming contours, as in [5].) With the identity $\coth(x) - 1 = 1/[e^{2x} - 1]$ we carry out the subtraction in $\Delta(f)$ and we arrive, finally, at

THE ABEL-PLANA SUMMATION FORMULA. *If $f(z)$ is analytic on the $1/2$ plane $\operatorname{Re}\{z\} > -\delta$, for some $\delta > 0$, and if both $\sum_{n=0}^\infty f(n)$ and $\int_0^\infty f(x) dx$ converge, then*

$$\Delta_0^\infty(f) = \frac{1}{2}f(0) + i \int_0^\infty \frac{f(iy) - f(-iy)}{e^{2\pi y} - 1} dy.\tag{12}$$

This is a rather elegant result. It is also a little bit strange; the difference between a *real* sum and integral of a function of a *real* variable is now expressed as a single integral with the function having a pure imaginary argument. As a check, let us apply this formula to Casimir's function $f(x) = x^3 e^{-\lambda x}$:

$$\begin{aligned}\Delta_0^\infty(x^3 e^{-\lambda x}) &= -2 \int_0^\infty \frac{y^3 \cos(\lambda y)}{e^{2\pi y} - 1} dy && (\lambda \rightarrow 0^+) \\ &= -\frac{2}{(2\pi)^4} \int_0^\infty \frac{t^3}{e^t - 1} dt && (t = 2\pi y) \\ &= -\frac{2}{(2\pi)^4} 3! \zeta(4) \\ &= -\frac{1}{120},\end{aligned}$$

the same number as before. We have used an integral representation for the **Riemann zeta function**

$$\zeta(n) = \frac{1}{(n-1)!} \int_0^\infty \frac{t^{n-1}}{e^t - 1} dt \quad (n = 1, 2, \dots)\tag{13}$$

and the fact that $\zeta(4) = \pi^4/90$. (See [4] or [5].) It is curious that the result of $-1/120$ comes from B_4 in the EMSF and from $\zeta(4)$ here. Are the two related? Indeed they are; notice that the generating function for the $B_n(x)$ has a form very

similar to the integral representation for $\zeta(n)$. It in fact can be shown that

$$\zeta(2m) = \frac{(2\pi)^{2m}}{2(2m)!} |B_{2m}| \quad (m = 1, 2, \dots). \quad (14)$$

(See, for example, [5].) Could this somehow be used to relate the two different summation formulas? The answer is yes.

A relationship between the two formulas Recall that in the APSF we assumed that $f(z)$ is analytic in some open $1/2$ plane $\text{Re}\{z\} > -\delta$, which includes the origin. Thus $f(z)$ has (appropriately enough) a **Maclaurin expansion** in this region given by: $f(z) = \sum_{n=0}^{\infty} f^{(n)}(0)z^n/n!$ If we insert this expansion into the AP prescription, and further restrict ourselves to functions $f(z)$ which allow the integral in the APSF to converge uniformly so that we may interchange the Σ and \int , we can integrate the series term-by-term

$$\begin{aligned} \Delta_0^\infty(f) &= \frac{1}{2}f(0) + i \sum_{n=0}^{\infty} \left\{ \frac{f^{(n)}(0)}{n!} \left[\int_0^\infty \frac{(iy)^n - (-iy)^n}{e^{2\pi y} - 1} dy \right] \right\} \\ &= \frac{1}{2}f(0) + i \sum_{k=1}^{\infty} \left\{ \frac{(-1)^k f^{(2k-1)}(0)}{(2k-1)!(2\pi)^{2k}} \int_0^\infty \frac{t^{2k-1}}{e^t - 1} dt \right\} \\ &= \frac{1}{2}f(0) - i \sum_{k=1}^{\infty} \frac{B_{2k}}{(2k)!} f^{(2k-1)}(0), \end{aligned}$$

which is precisely the Euler-Maclaurin formula! (In the special case where N and $K \rightarrow \infty$, i.e., $f(x)$ is integrable in the AP expression and has continuous derivatives of all orders—which of course it does since it is in a region where it is analytic.)

Conclusions So we have come full circle. We have seen how a question posed in theoretical physics has led us to consider some really nice, old formulas from classical analysis. These we saw could be used to compute results to take us back to the physics again—this time in the laboratory. It is to be hoped that in the process we have gained insight into why, for some people at least, doing mathematics and physics together can be more stimulating than doing either one separately—not to mention it's downright *fun*.

REFERENCES

1. H. G. B. Casimir, On the attraction of two perfectly conducting plates, *Proc. Kon. Akad. Ned. Wet.* 51 (1948), 793–795.
2. T. H. Boyer, The classical vacuum, *Scientific American* 253 (1985), 56–63.
3. E. A. Power, *Introductory Quantum Electrodynamics*, Longmans, London, 1964, Appendix 1. (A more accessible account of the Casimir effect, as well as a good beginning test for QED. Warning! Some knowledge of physics may be required.)
4. G. P. Carrier, M. Krook and C. E. Pearson, *Functions of a Complex Variable*, McGraw-Hill, New York, 1966.
5. G. H. Hardy, *Divergent Series*, Oxford Press, London, 1963, Chapter XIII. (The last book that Hardy wrote; a masterpiece of classical analysis.)